

INSTRUCTIONS FOR STRAIGHTAWAY 216

MAXIMUM WEIGHT OF DOOR 250kg (550 lb).
MAXIMUM DOOR HEIGHT 4.0m (13ft).
TIMBER DOOR THICKNESS 35mm TO 44mm.
METAL DOOR THICKNESS 40mm MINIMUM.

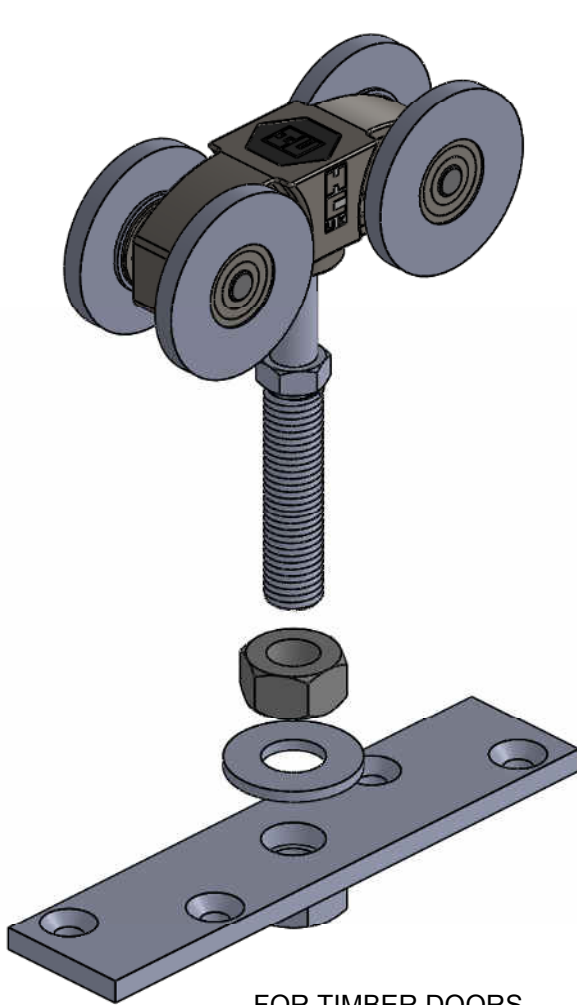

FOR TIMBER DOORS

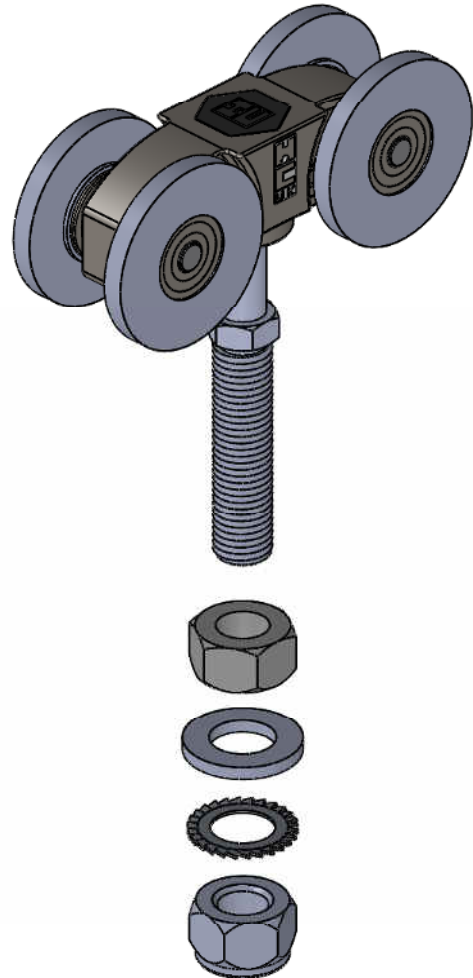

FOR METAL DOORS

COMPONENTS:

- 2-16 STEEL TRACK
- 2-100 SIDE WALL BRACKET
- 2-051 CLOSED END PIECE
- 2-002 LOCK JOINT KIT
- 2-248 FOUR WHEEL HANGERS
- 2-249 FOUR WHEEL HANGERS
- 44-1 STEEL CHANNEL
- 44-2 ALUMINIUM CHANNEL
- 44-010 CHANNEL LUG PACK
- 44-011 CHANNEL SHOE
- 95-605 BOW HANDLE STEEL
- 95-560 DROP BOLT
- 95-616 FLUSH HANDLE
- 97-711 WALL DOOR STOP 'SMALL'
- 44-319 ROLLER GUIDES
- 44-347 CONCEALED GUIDE
- 02718 TRACK END STOP

These instructions should be treated as general guidance instructions; variations to the procedure may change depending upon site requirements.

Securely fix the **Side Wall Brackets** to lintel perfectly level throughout. Do not fit the side wall bracket at the furthest end only mark its position on the lintel, this will be fixed after the track is fitted.

Fit a **Closed End Piece** in the side wall bracket at the start.

Fixing bolts to be compatible with type of lintel.

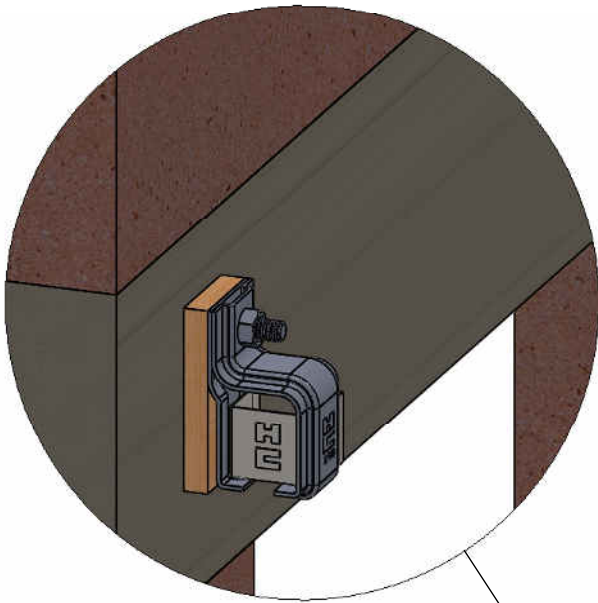

FIG. 2

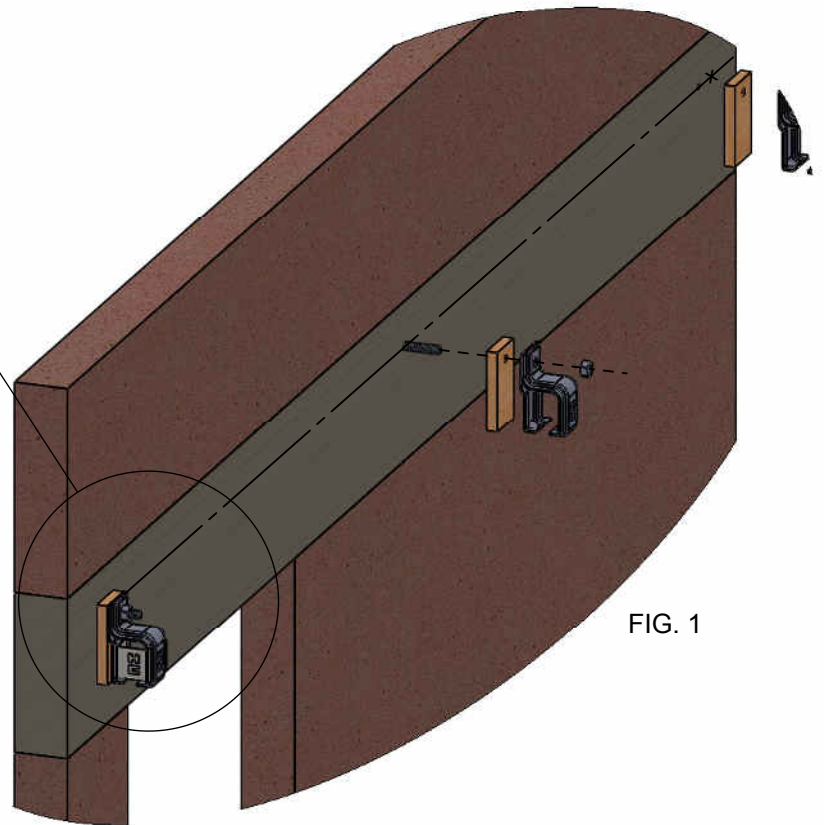

FIG. 1

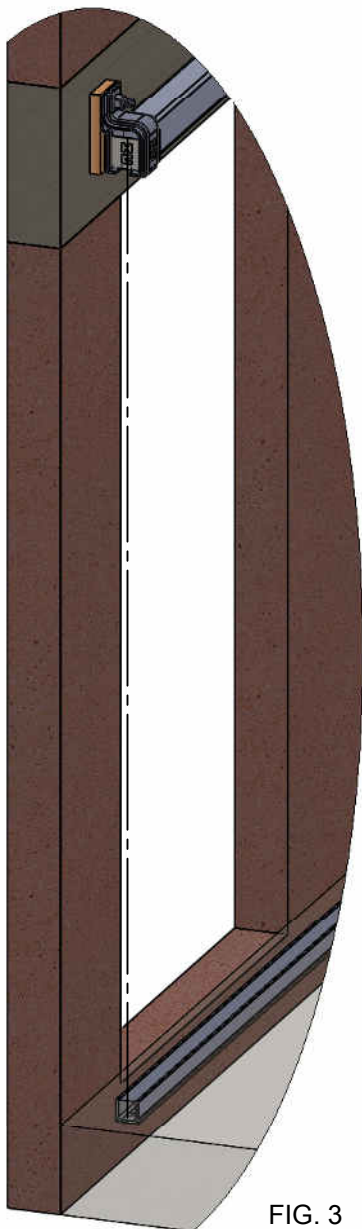

FIG. 3

Fit **2-16 track** through the side wall brackets mounted on the lintel.

Fix **Floor Channel** so that centre of channel is plumb with centre of top track, using a plumb bob or a spirit level hung centrally in track.

TIMBER DOORS

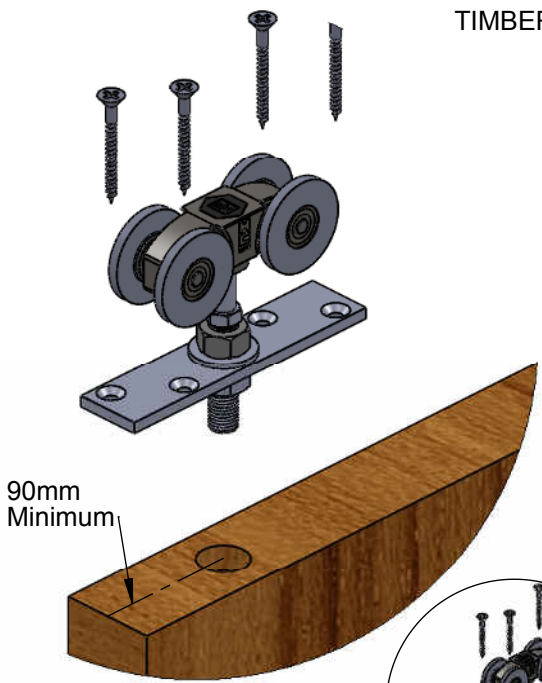

FIG. 5

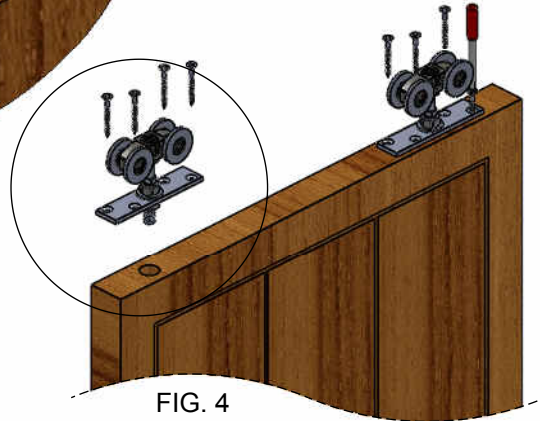

FIG. 4

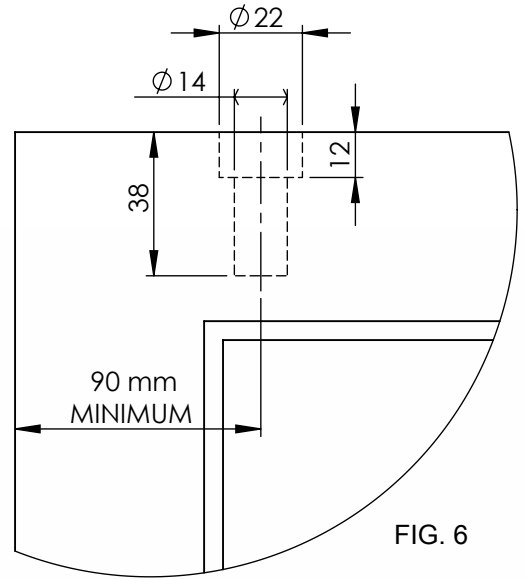

FIG. 6

Drill holes on top edge of door for pendant bolts, make recesses for nuts allowing 6mm lateral movement, as shown in fig.6 (timber doors only).

Fit **Hanger assembly** with top plate positioned in line with the holes on the top edge of the door.

Fit **Bottom Concealed Guides** on the bottom edge of the door using the appropriate fixings supplied as shown in fig.7 & 8.

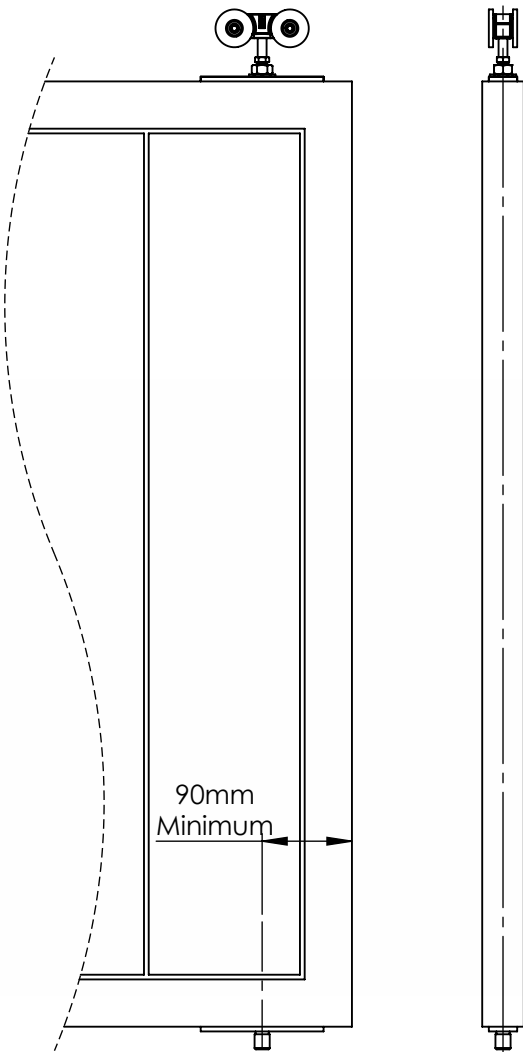
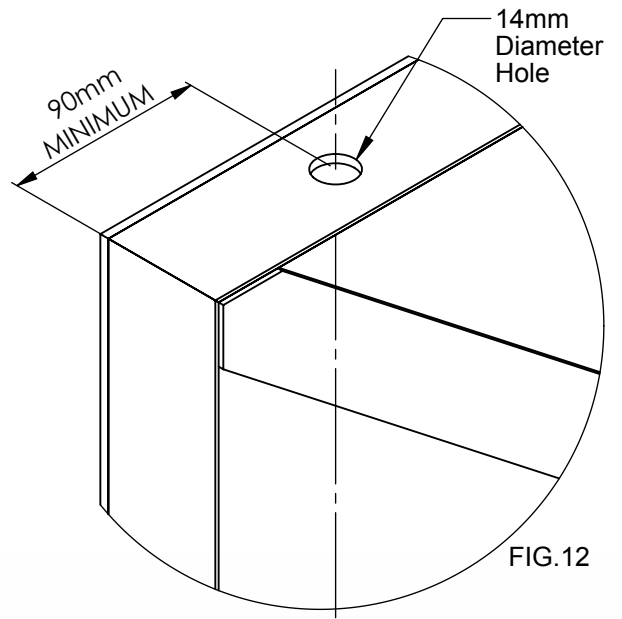
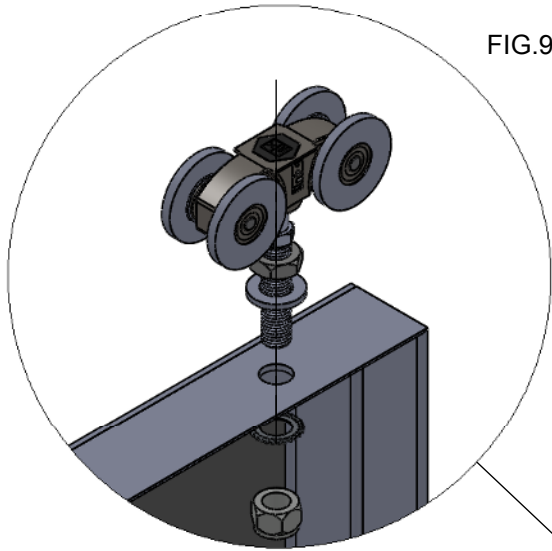

FIG.8

METAL DOORS



Drill two 14mm diameter holes on the top and two on the bottom edge of the door as shown in fig.12 & 13. Make sure the holes are laterally in line.

Fit **Hangers assembly** with pendant bolt locating through the 14mm holes. Secure the hanger using the **M12 'Staytite' Nut** as shown in fig.9.

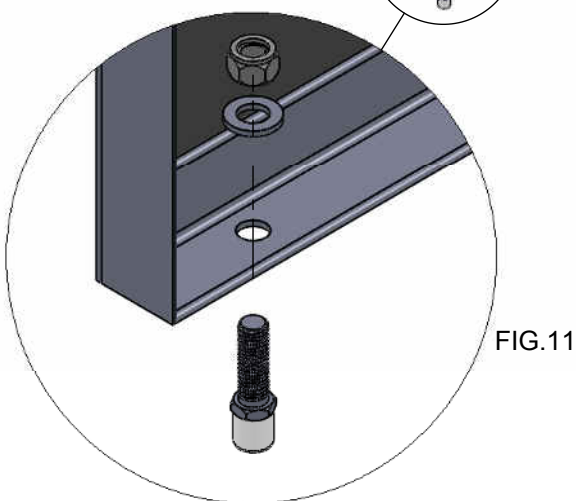
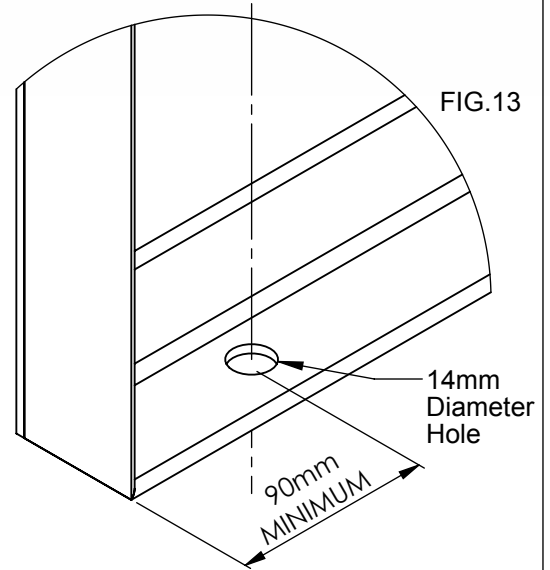
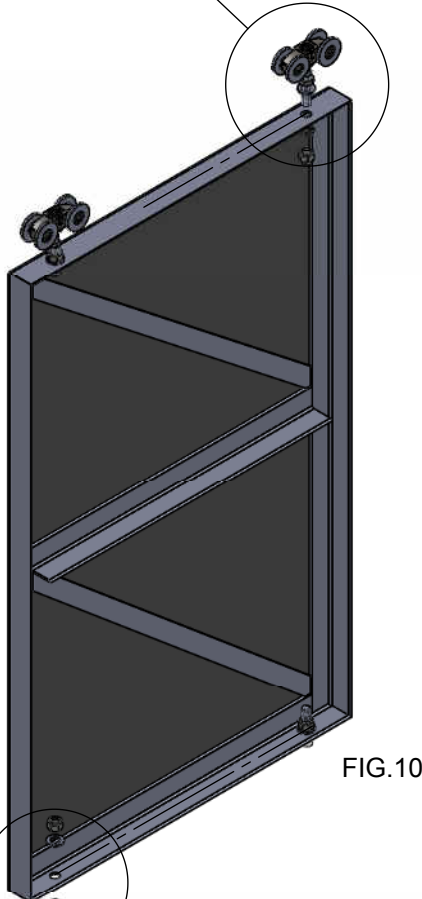

Fit **Bottom Roller Guides** on the bottom edge of the door using the appropriate fixings supplied as shown in fig.11.

Raise doors and centre hangers into track, as shown in fig.14.

Fit Side Wall Bracket that was left out, fitted with Closed End Piece to open end of track before securing it to the lintel, see fig.15.

Adjust hangers to obtain correct clearance under door, adjust laterally as required and tighten lock nuts, see fig.16.

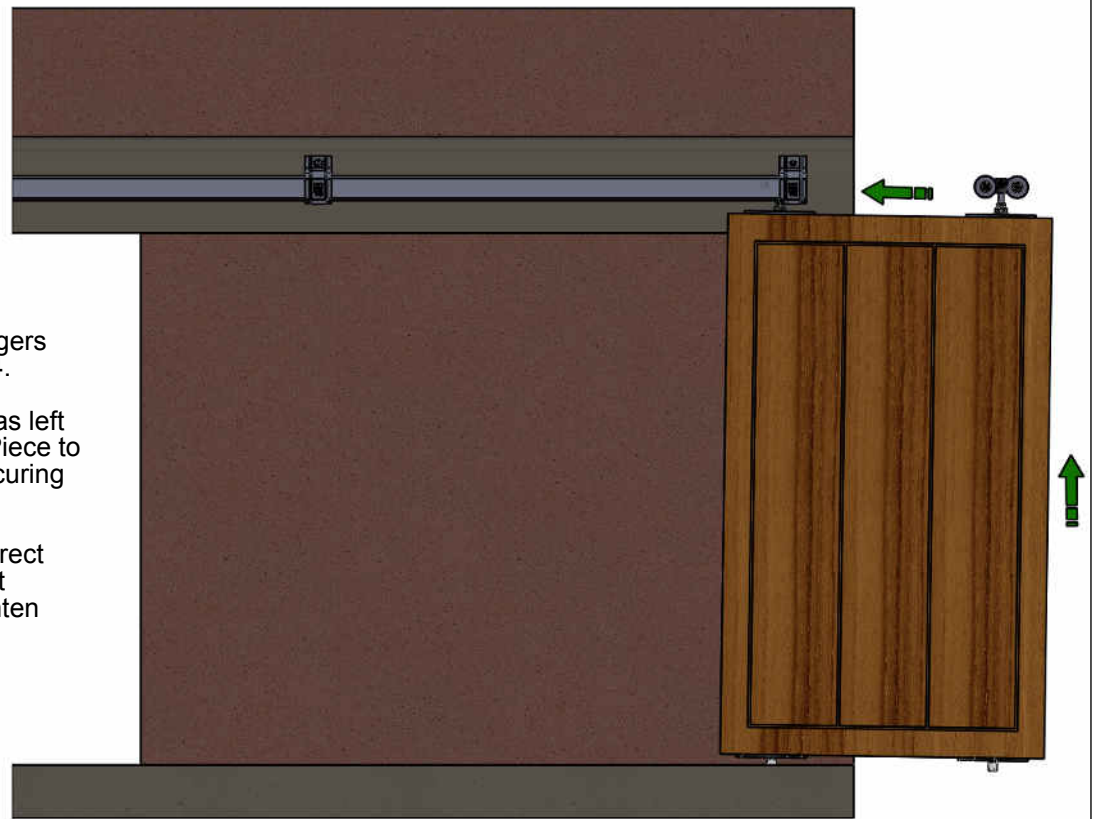

FIG.14

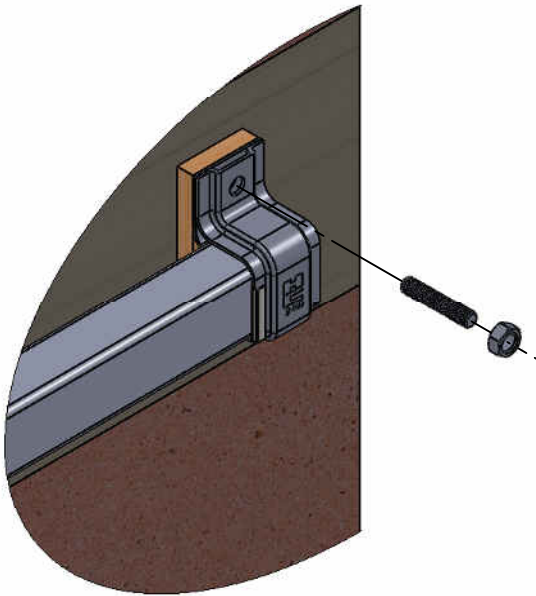

FIG.15

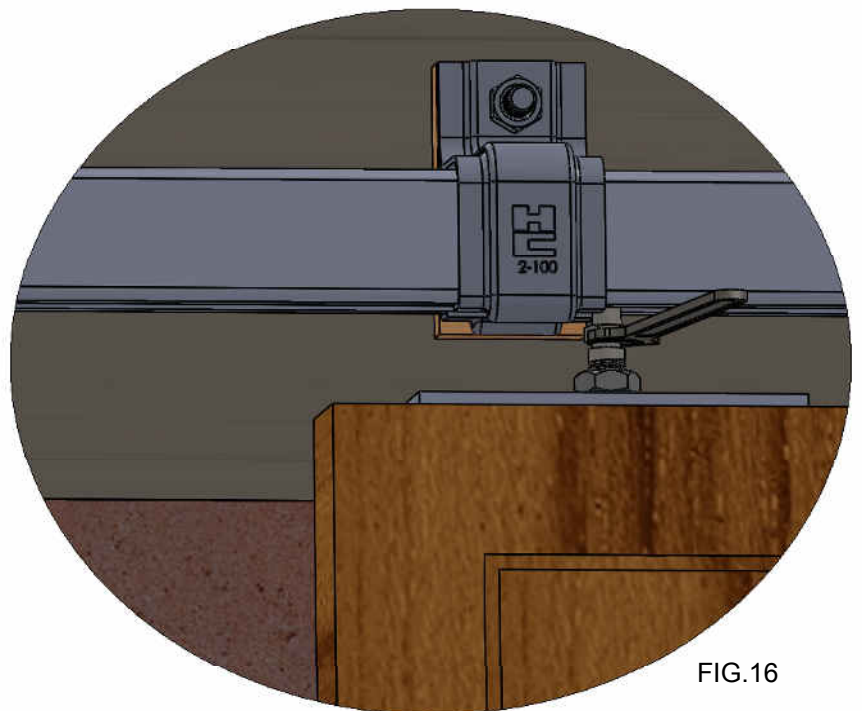

FIG.16

Where it is not possible to slide the door in from one end with hangers already fitted, it may be necessary to cut the track in half; in this case the **Lock Joint Kit** should be used in conjunction with an intermediate bracket where the join occurs as shown in fig.17.

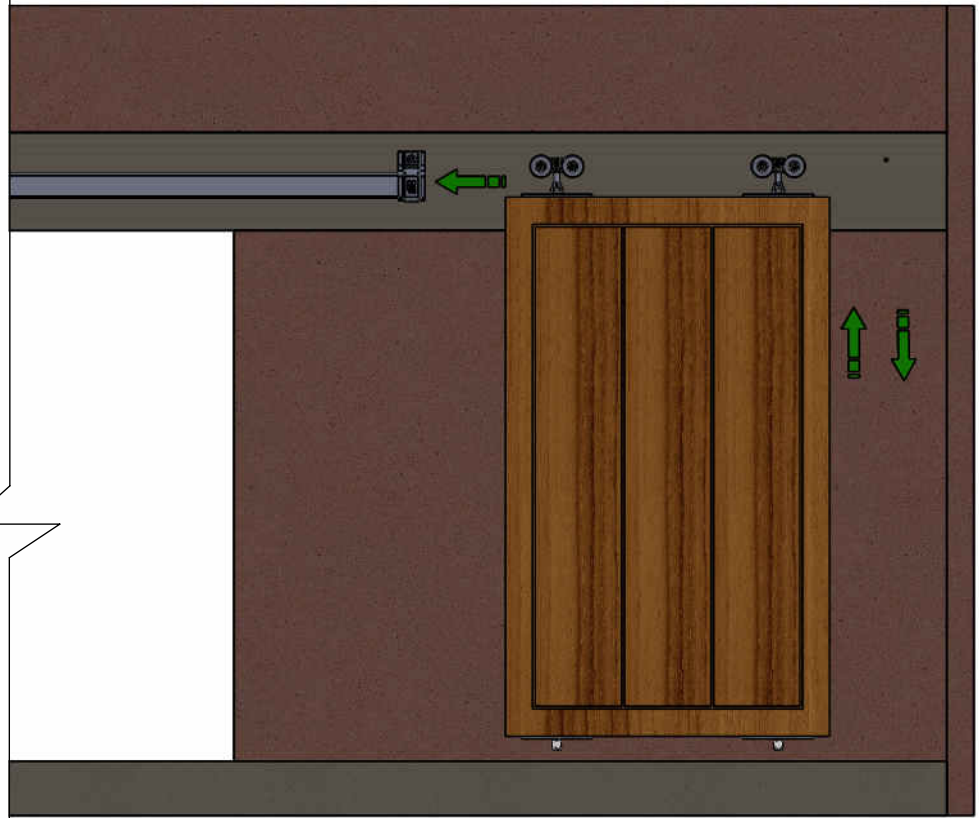
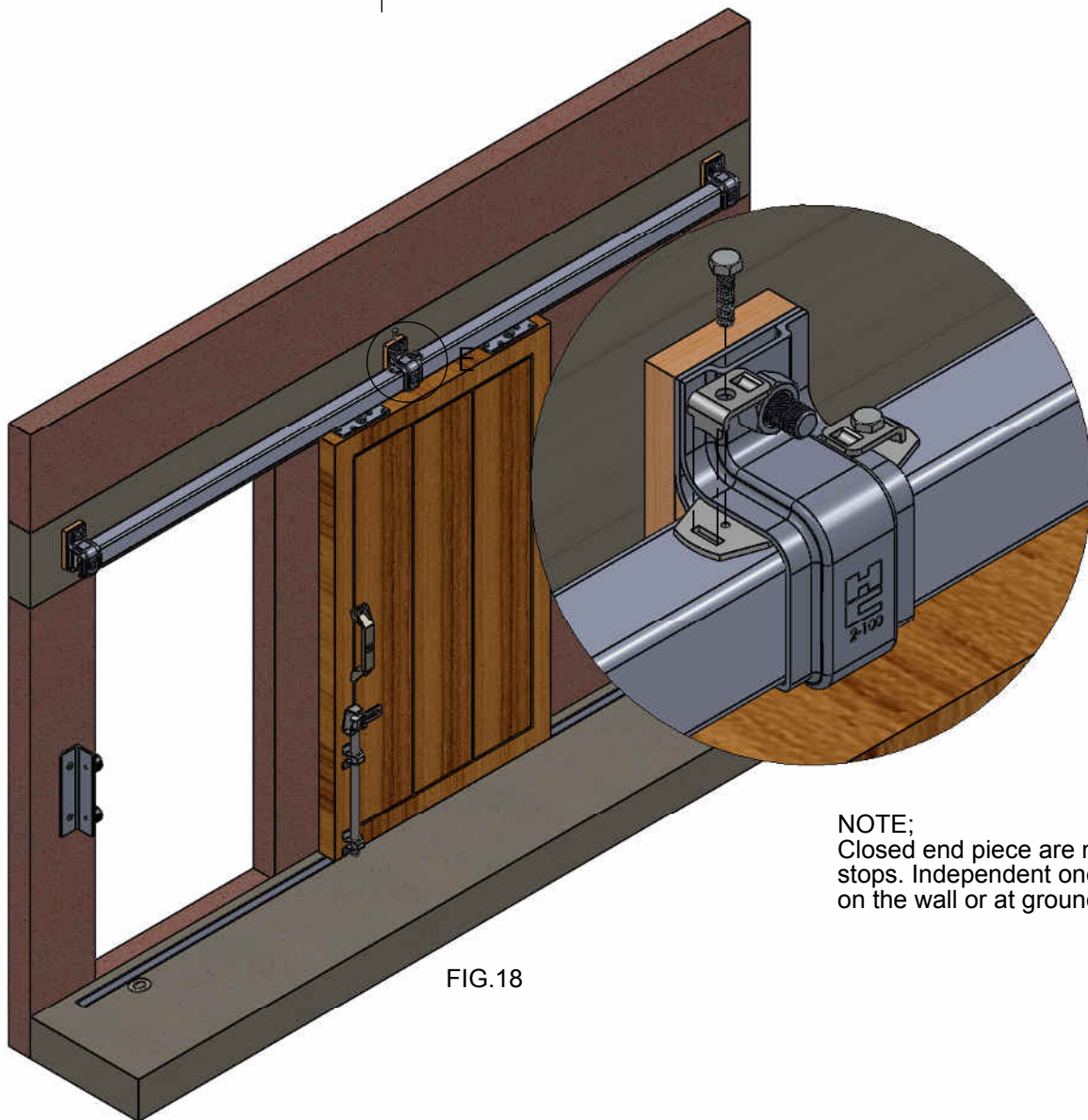

FIG.17



Fit **Door Stops** to prevent hangers clashing with closed end brackets, see fig.18.

NOTE;
Closed end piece are not to be treated as door stops. Independent ones should be used either on the wall or at ground level.

FIG.18

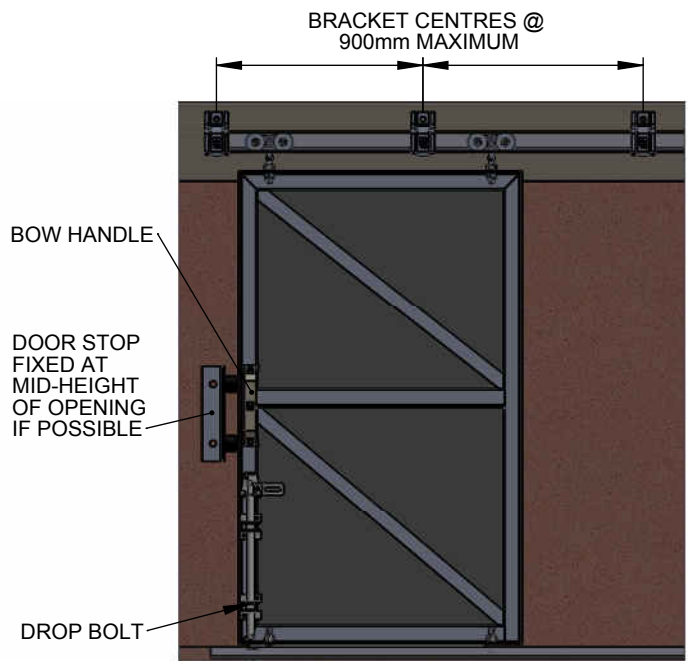
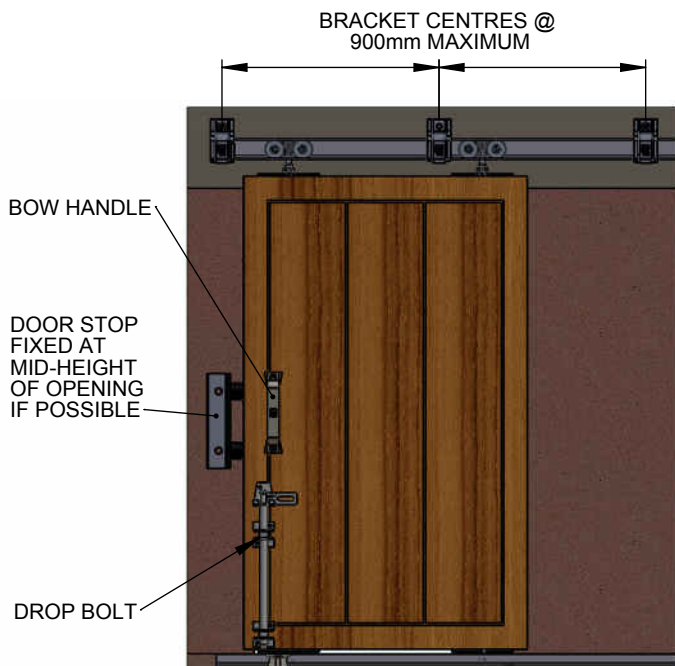
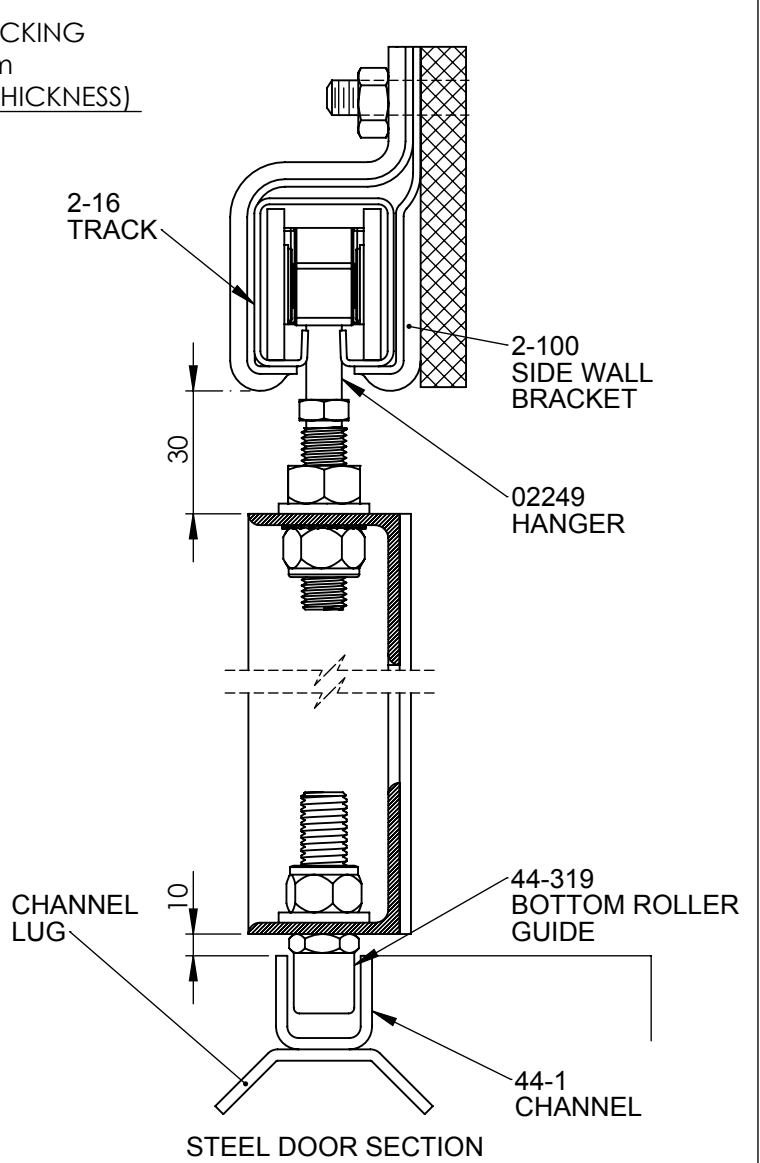
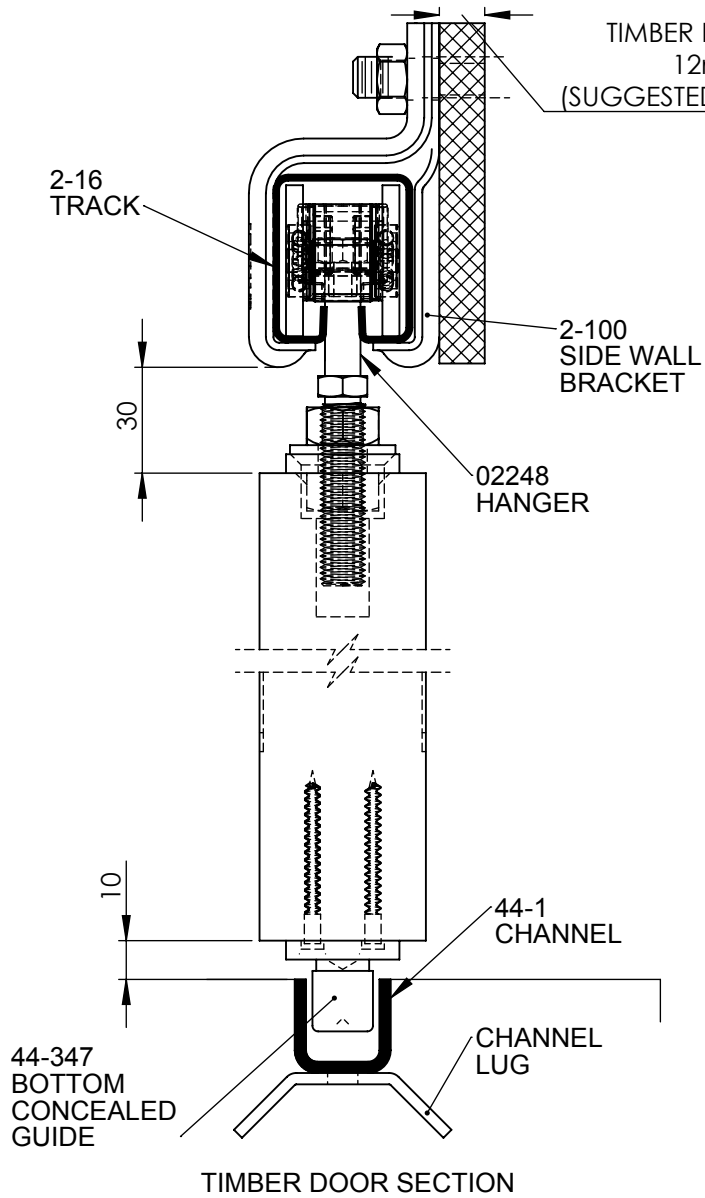

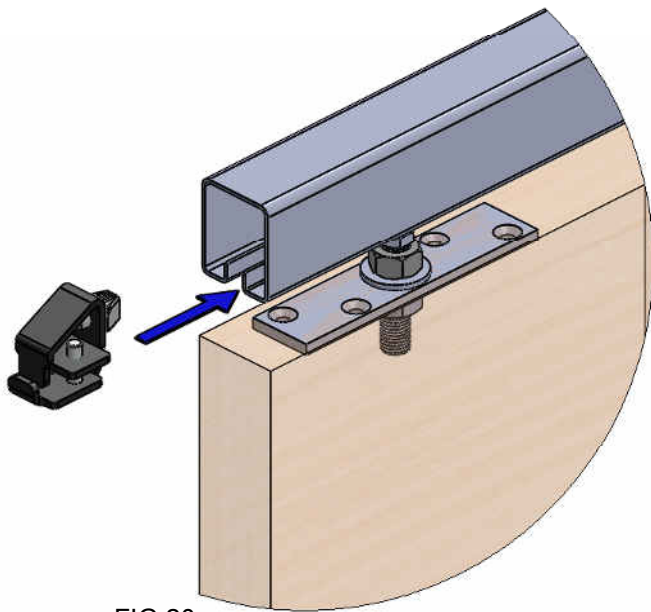

FIG.20



Track End Stop 02718

Note:
In Fig20 blue arrow shows the 02718 track stop inserted into the track. Then use allen key to tighten the screws.

Note:
Fig21 shows the 02718 track stop is fixed flushed to the edge of the track.

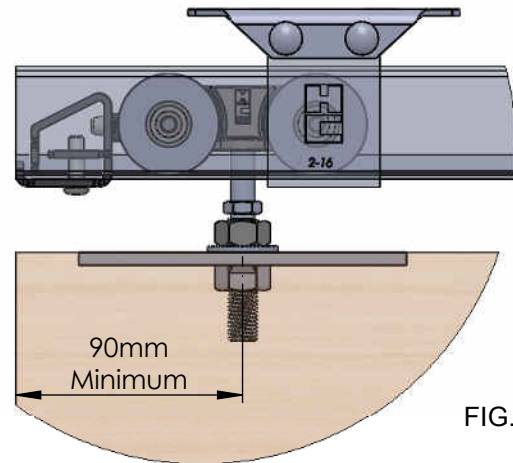

FIG.21

MAINTANANCE:

Clean out channel, grease copiously inside of the top track and repeat at intervals.
Check all bolts, nuts and screws are securely tightened.

© HILLALDAM COBURN LTD
UNIT 16, MERTON INDUSTRIAL PARK
LEE ROAD, LONDON
SW19 3HX, ENGLAND
TEL: +44 (02)0 8545 6680
FAX: +44 (02)0 8545 6723
e-mail: sales@hillaldam.co.uk
www.coburn.co.uk

 **COBURN**
SLIDING SYSTEMS

The company reserves the right to make alteration in design and manufacture as they consider necessary without notice from time to time.

STRAIGHTAWAY 216 Fitting Instructions

Max weight: 250Kg, Max height:4m, Thickness: 35-45mm

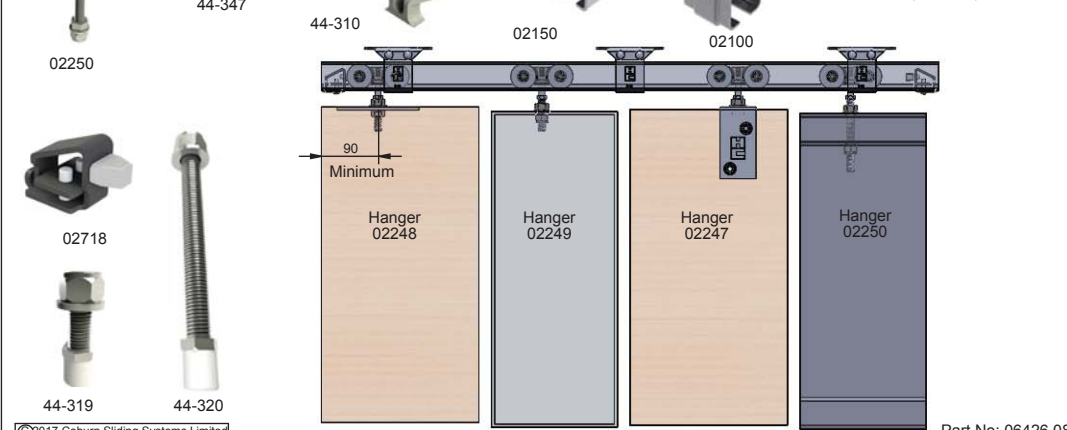
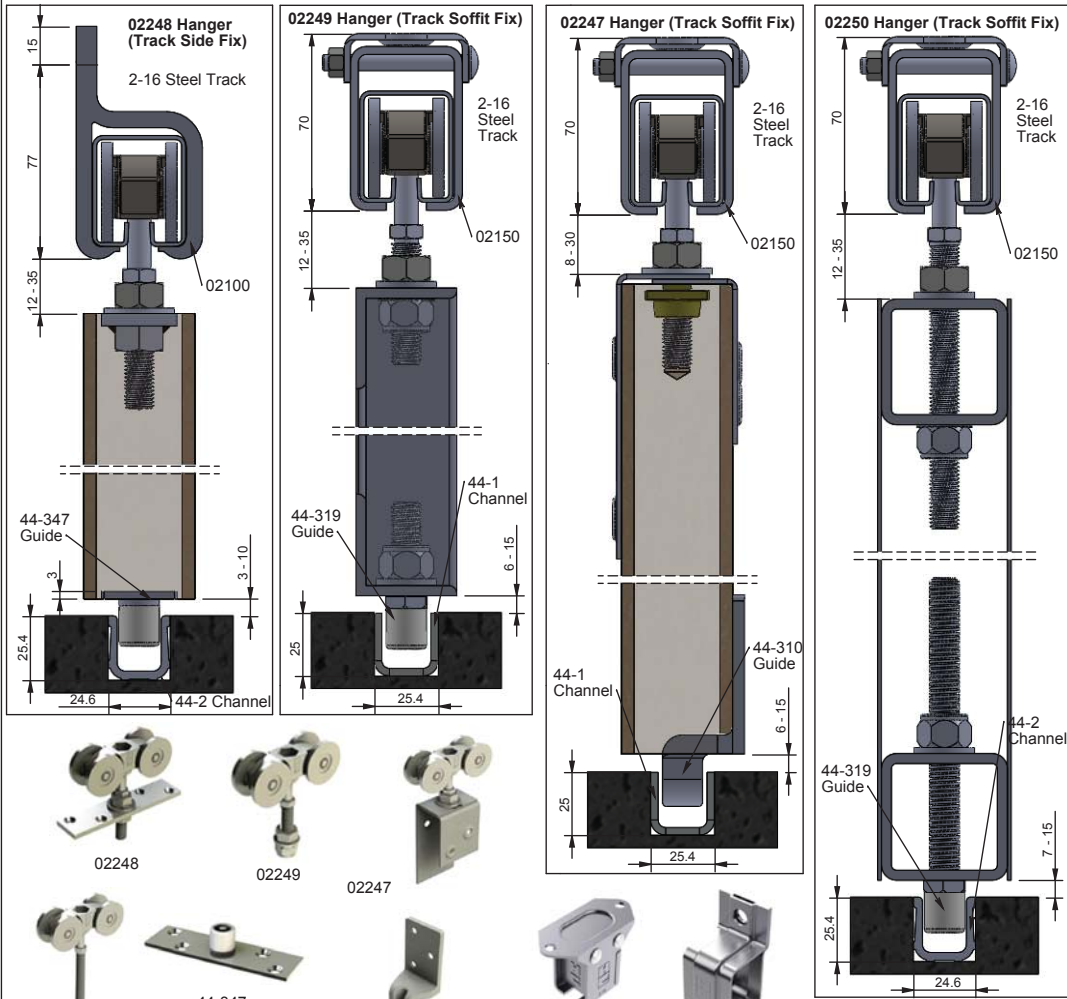

STRAIGHTAWAY 216 Fitting Instructions

Max weight: 250Kg, Max height:4m, Thickness: 35-45mm

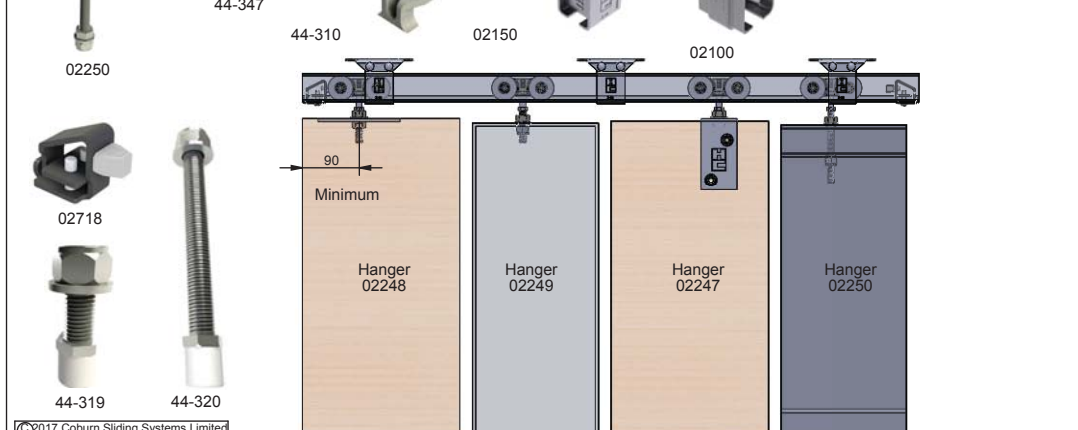
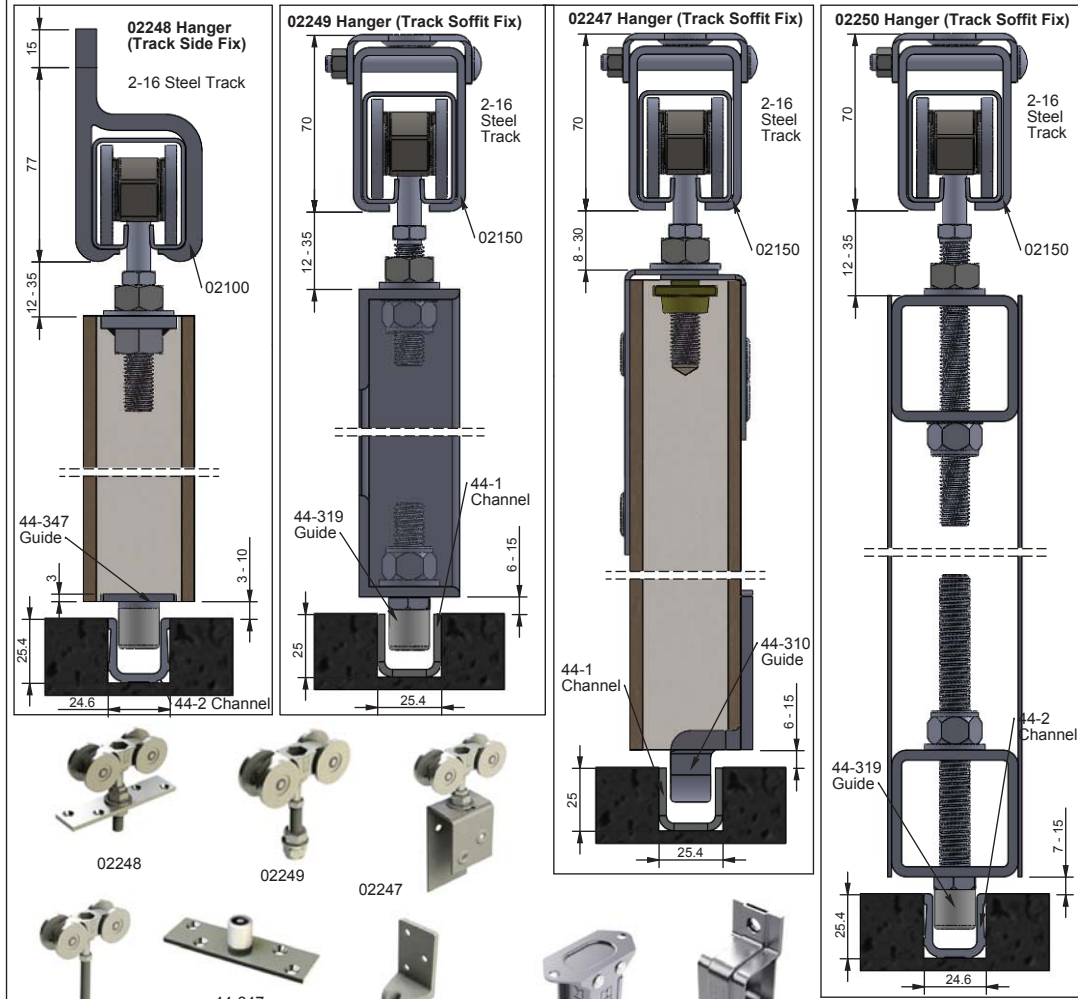

Addition of half nuts on the hanger Assembly:

Before inserting pendant bolt into the hanger, put half nuts part no: 03025.131(see fig A) on to the pendant bolt and then insert pendant bolt through centre hole of the hanger.

Hangers required half nut:
02247
02248
02249
02250

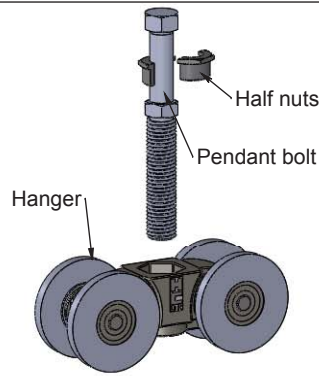

(Fig A)

Addition of half nuts on the hanger Assembly:

Before inserting pendant bolt into the hanger, put half nuts part no: 03025.131(see fig A) on to the pendant bolt and then insert pendant bolt through centre hole of the hanger.

Hangers required half nut:
02247
02248
02249
02250

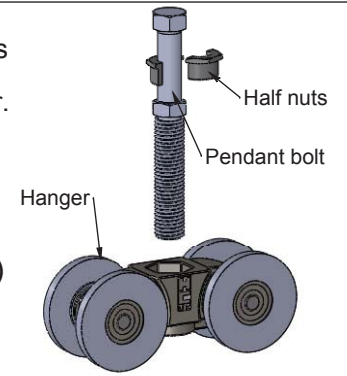

(Fig A)

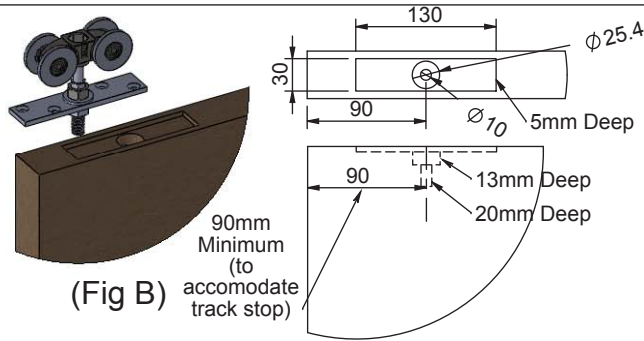

Fig B: Cut out for the hanger no: 02248

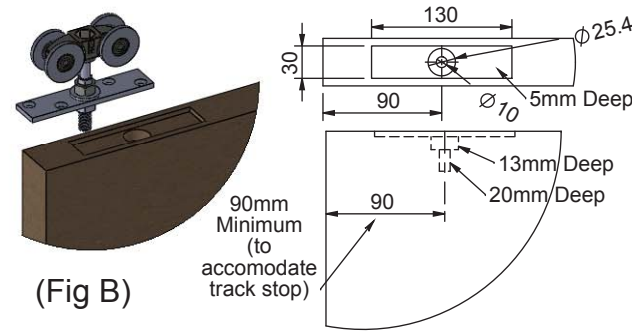

Fig B: Cut out for the hanger no: 02248

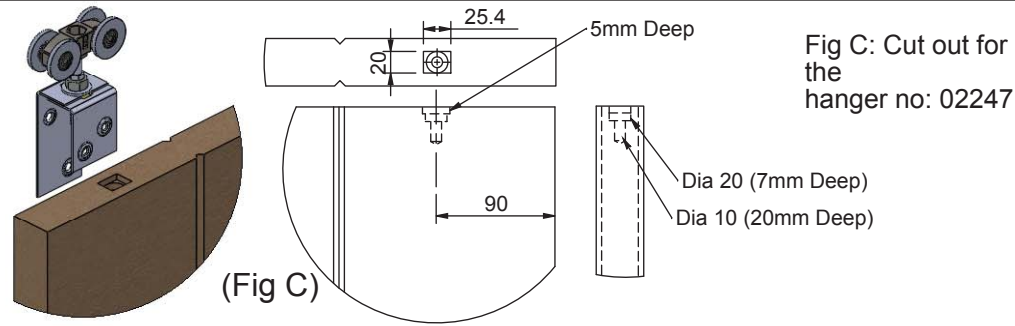

Fig C: Cut out for the hanger no: 02247

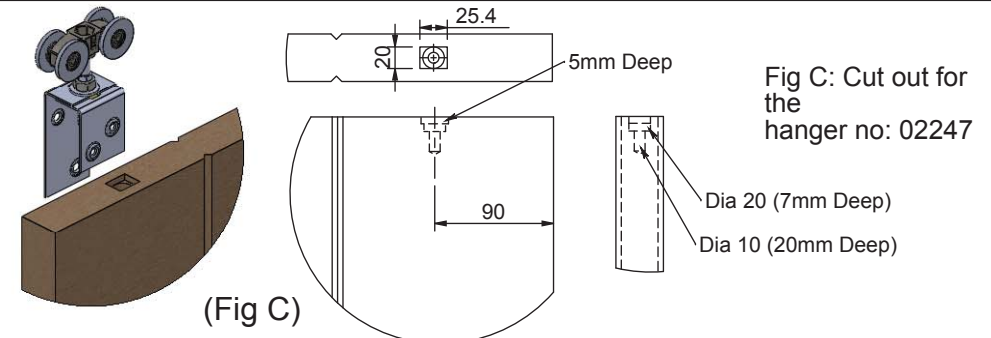
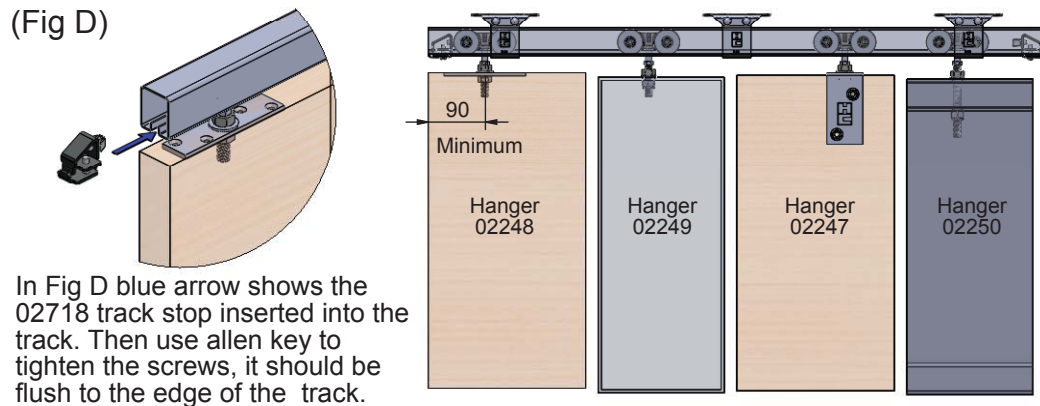
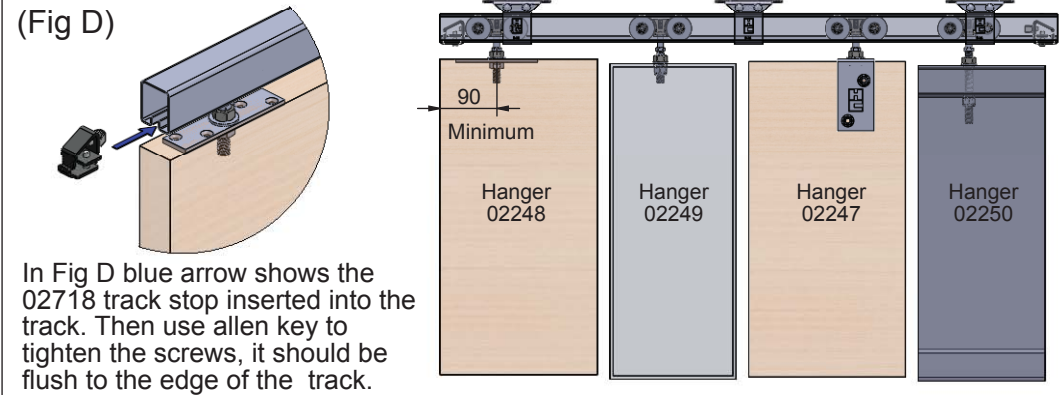

Fig C: Cut out for the hanger no: 02247



In Fig D blue arrow shows the 02718 track stop inserted into the track. Then use allen key to tighten the screws, it should be flush to the edge of the track.



In Fig D blue arrow shows the 02718 track stop inserted into the track. Then use allen key to tighten the screws, it should be flush to the edge of the track.

INSTRUCTIONS FOR STRAIGHTAWAY 216 (DOUBLE PARALLEL TRACK)

MAXIMUM WEIGHT OF DOOR 150kg (330 lb).
 MAXIMUM DOOR HEIGHT 2.7m (9ft).
 TIMBER DOOR THICKNESS 35mm TO 44mm.
 METAL DOOR THICKNESS 40mm MINIMUM.

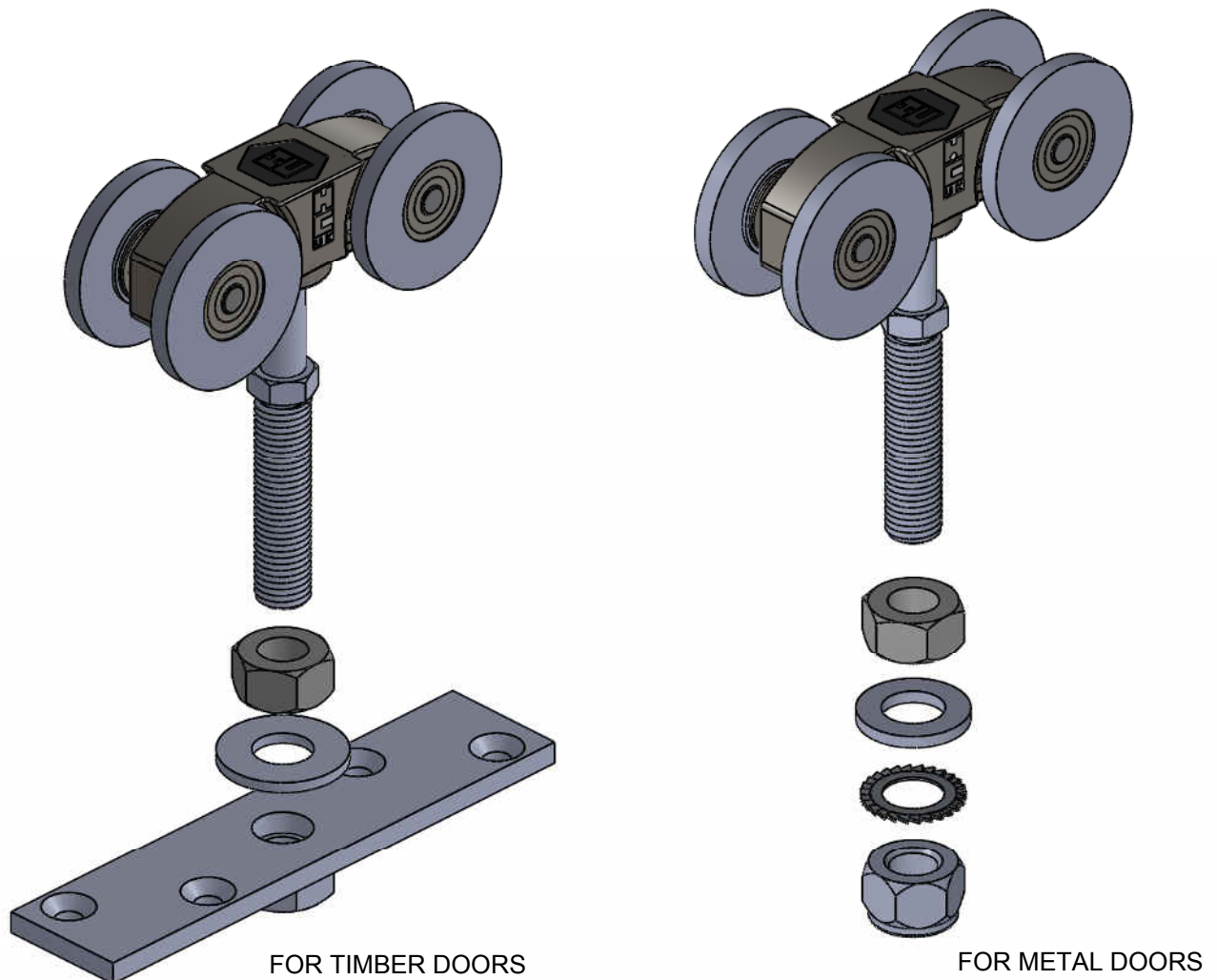

COMPONENTS:

- 2-16 STEEL TRACKS
- 2-130 DOUBLE SIDE WALL BRACKETS
- 2-132 LOCK-JOINT DOUBLE SIDE WALL BRACKETS
- 2-051 CLOSED END PIECES
- 2-248 FOUR WHEEL HANGERS (TIMBER DOORS)
- 2-249 FOUR WHEEL HANGERS (METAL DOORS)
- 44-1 STEEL CHANNELS
- 44-2 ALUMINIUM CHANNELS
- 44-010 CHANNEL LUG PACK
- 44-011 CHANNEL SHOES
- 95-605 BOW HANDLE STEEL
- 95-616 FLUSH HANDLE
- 3026.112 M12 'STAYTITE' NUT
- 3029.135 M12 'SHAKE PROOF' WASHER
- 44-319 ROLLER GUIDES
- 44-347 CONCEALED GUIDES
- 2-718 TRACK END STOP

NB

These instructions should be treated as general guidance instructions; variations to the procedure may change depending upon site requirements.
 Read the whole of the instructions before commencing installation.

TIMBER DOORS
(For metal doors see next page)

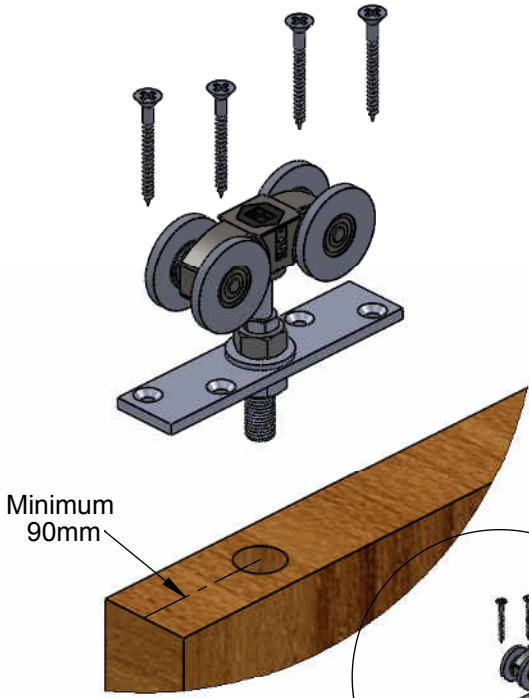

FIG. 1

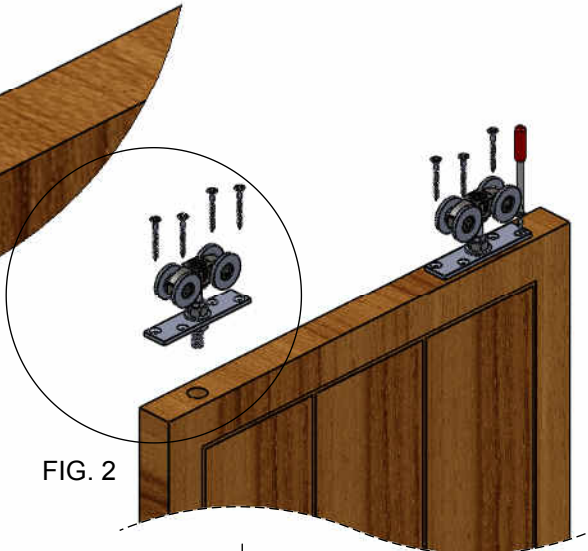

FIG. 2

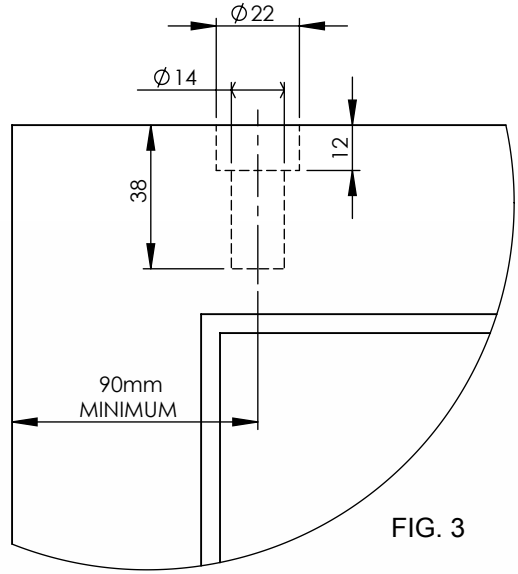

FIG. 3

Drill holes on top edge of door for pendant bolts, make recesses for nuts allowing 6mm lateral movement, as shown in fig.1 & 3 (timber doors only).

Fit **Hanger assembly** with top plate positioned in line with the holes on the top edge of the door. See fig.2

Fit **Bottom Concealed Guides** on the bottom edge of the door using the appropriate fixings supplied as shown in fig.4 & 5.

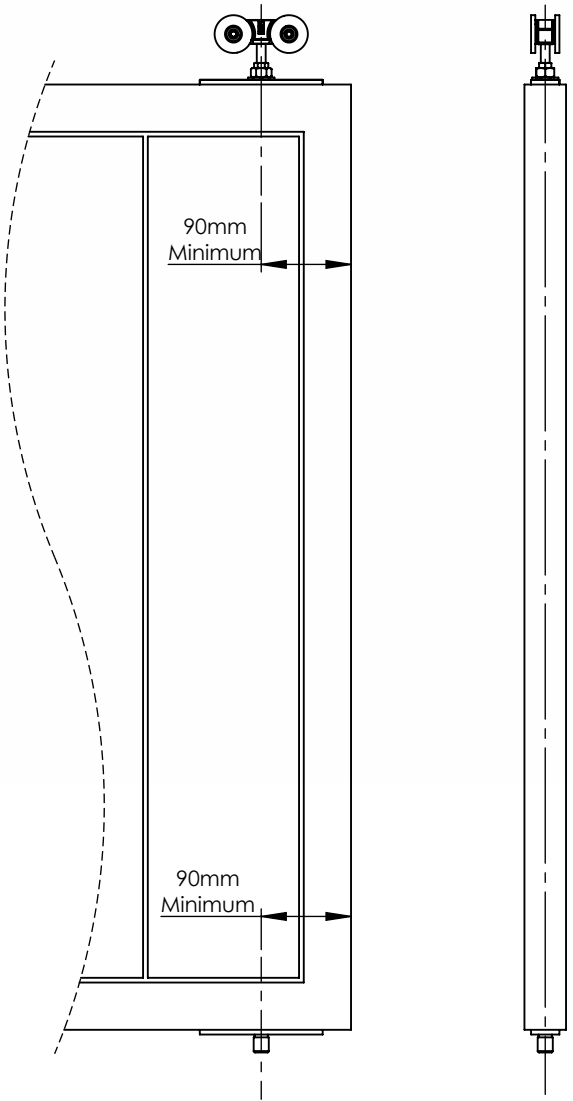
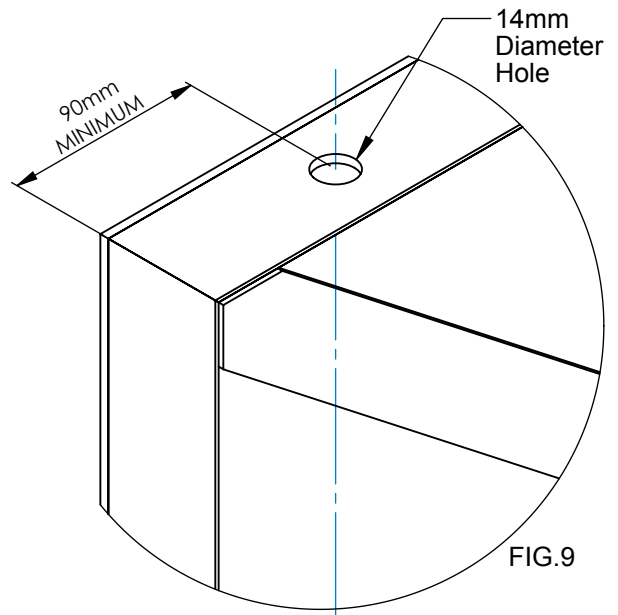
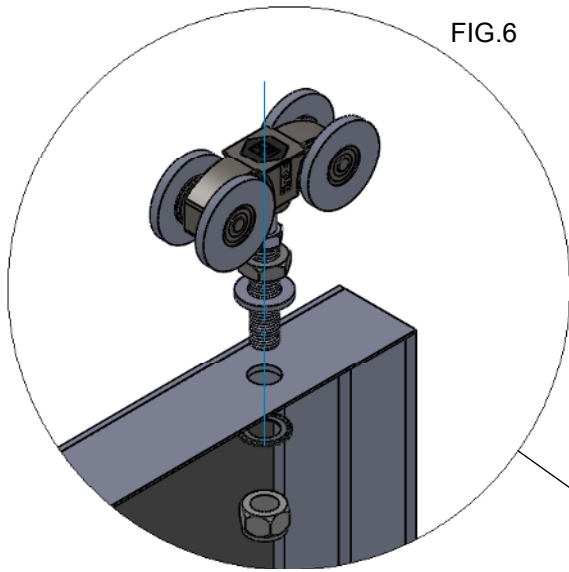

FIG.5

METAL DOORS



Drill two 14mm diameter holes on the top and two on the bottom edge of the door as shown in fig.9 & 10. Make sure the holes are laterally in line.

Fit **Hangers assembly** with pendant bolt locating through the 14mm holes. Secure the hanger using the **M12 'Staytite' Nut** as shown in fig.6.

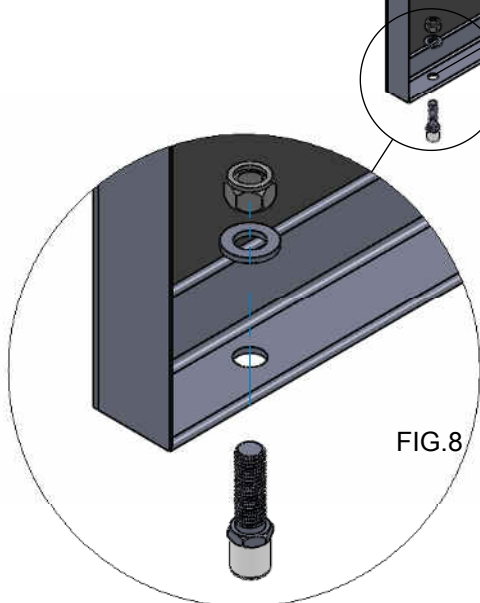
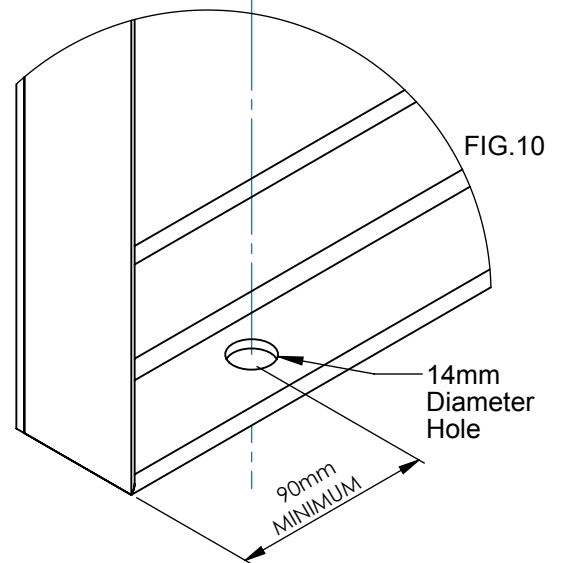
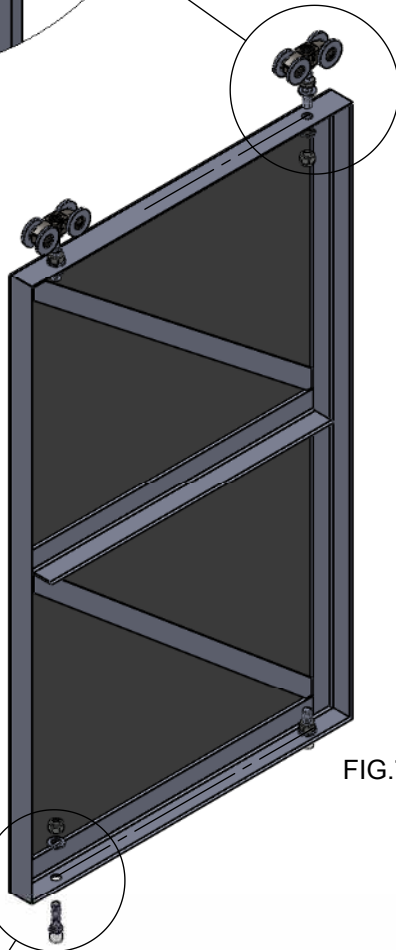

Fit **Bottom Roller Guides** on the bottom edge of the door using the appropriate fixings supplied as shown in fig.8.

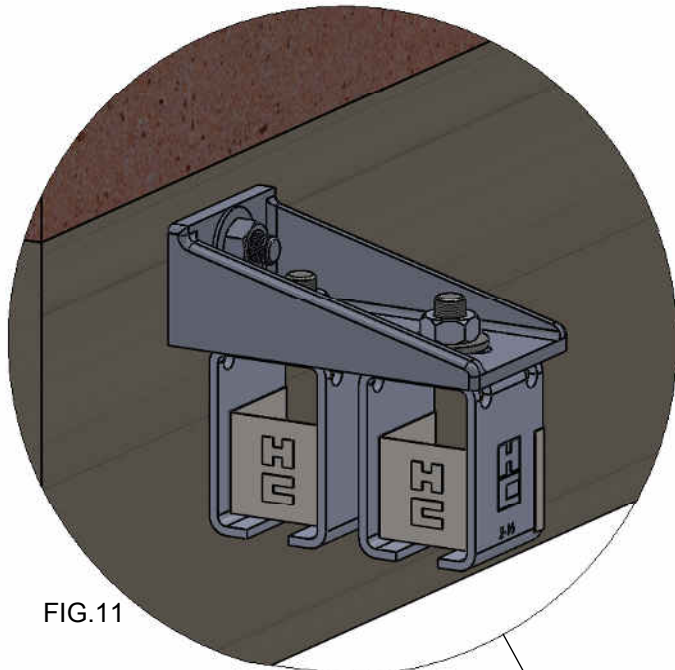

FIG.11

Securely fix the **Double Side Wall Brackets** to the lintel perfectly level throughout, except for the one at the furthest end to the door opening, which should be temporarily fitted with the **Closed End Pieces** in place. This will be fixed after the hangers are securely in the tracks. See fig.11 & 12

Fit a Closed End Piece in the Side Wall Bracket nearest to the door opening. See fig.11

NB
Fixing bolts to be compatible with type of lintel.

Where deemed necessary, use timber packers to ensure brackets are fixed in line.

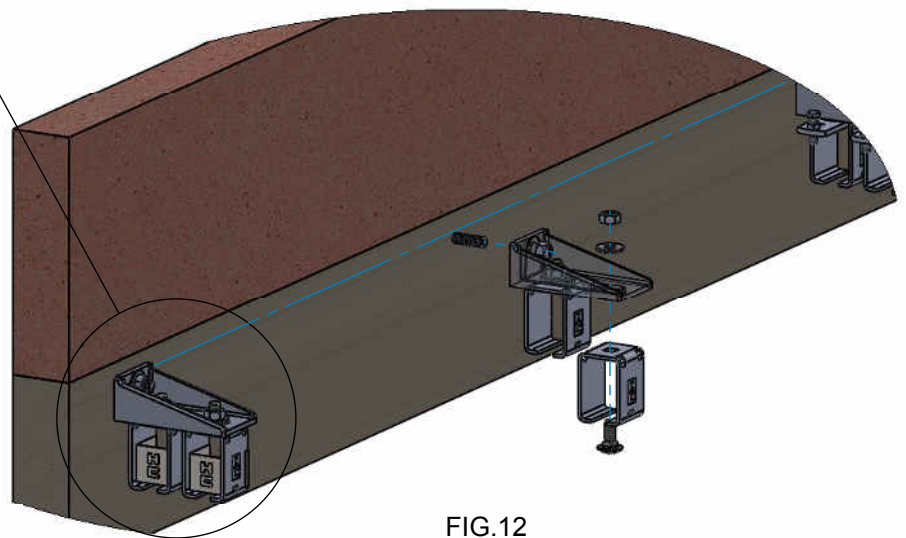

FIG.12

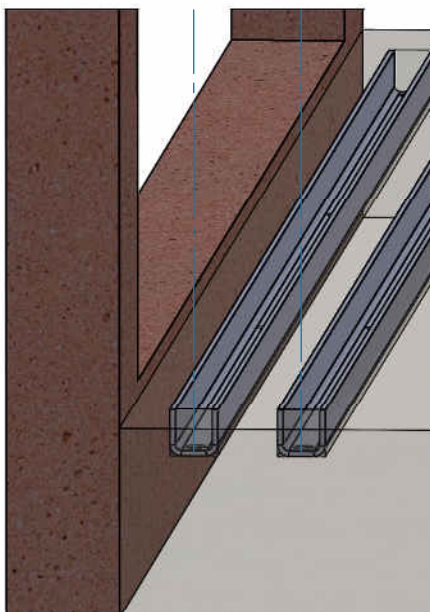
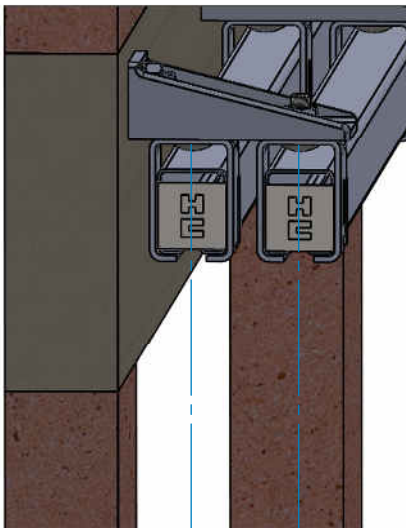

FIG.13

Fit **2-16 tracks** through the Double Side Wall Brackets mounted on the lintel. See fig.13

Fix **Floor Channels** so that centre of channel is plumb with centre of top track, using a plumb bob or a spirit level hung centrally in track. Make sure the channel is flush with floor level.



Insert the first track through the brackets making sure it fits into the closed end piece. You might have to disassemble some of the brackets for easy access as shown in fig.14.

FIG.14

Raise doors and insert hangers into tracks. Reassemble some of the brackets to fit the second track, in line with the first.

Repeat these steps for the next row of track as shown in fig.15.

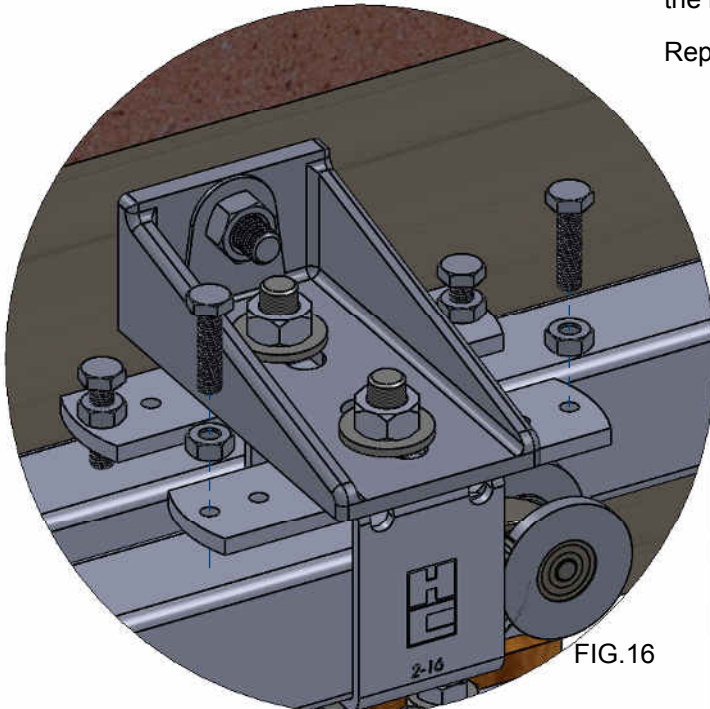

FIG.16

The lock-joint double side wall bracket should be used where the track join occurs. See fig.16

NB
Closed end piece **are not** to be treated as door stops. Independent ones should be used either on the wall or at ground level.



FIG.15

Slide the doors to the other end of the tracks before undoing the temporary fixed Double Side Wall Bracket so as to fit Closed End Pieces. Secure it to the lintel, see fig.17.

Adjust hangers to obtain correct clearance under door, adjust laterally as required and tighten lock nuts, see fig.18.

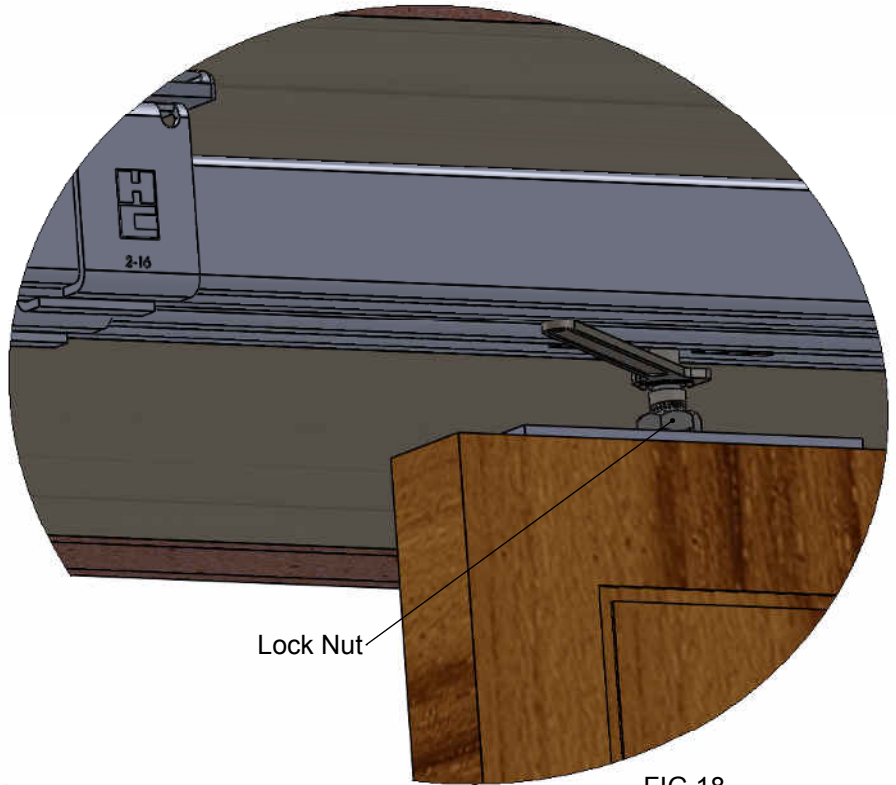

FIG.18

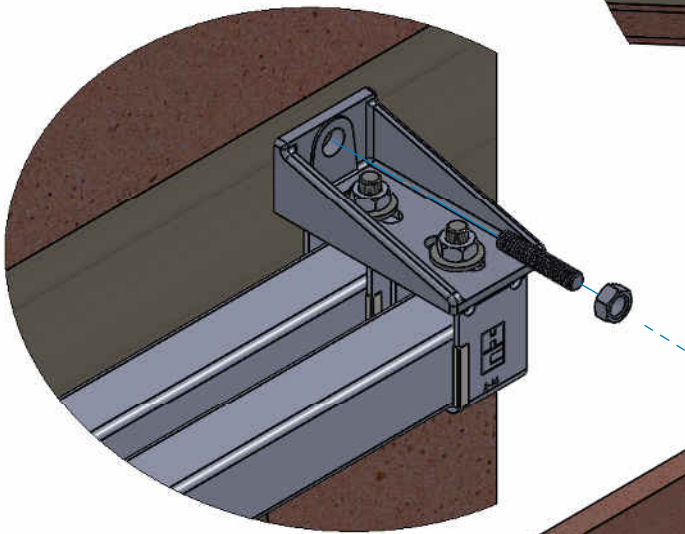

FIG.17

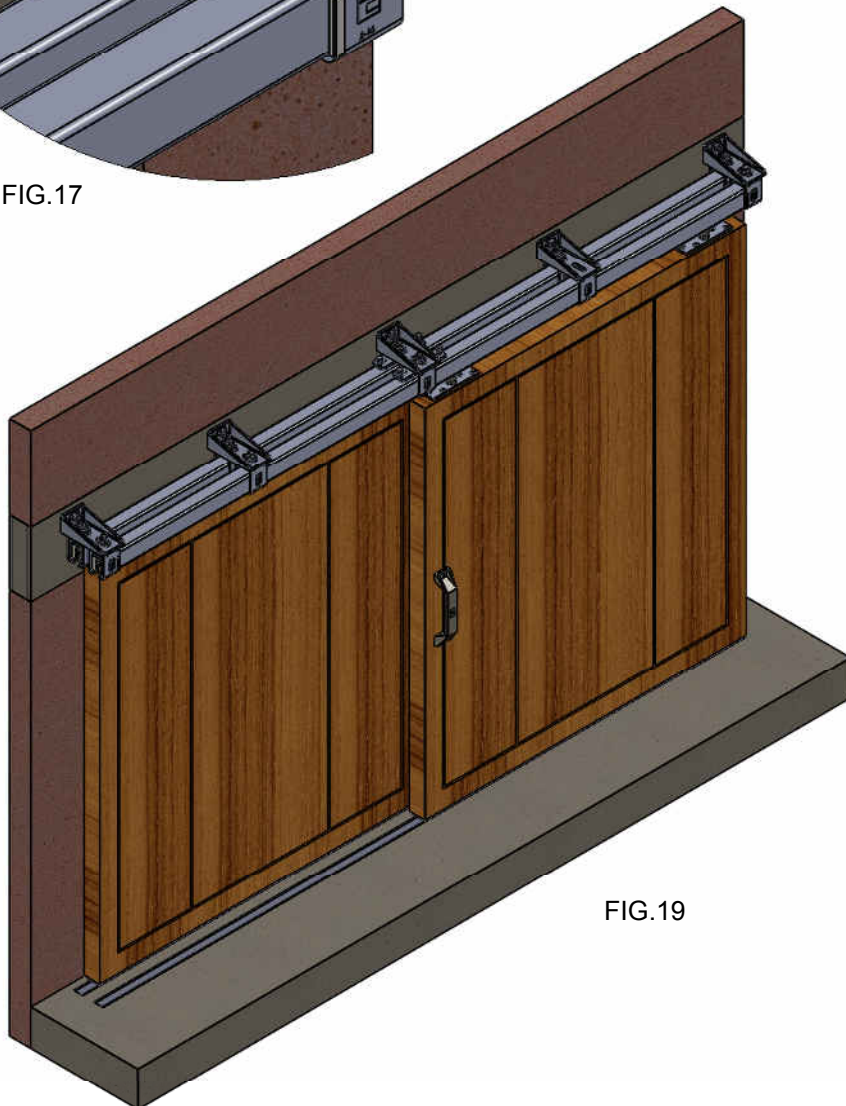
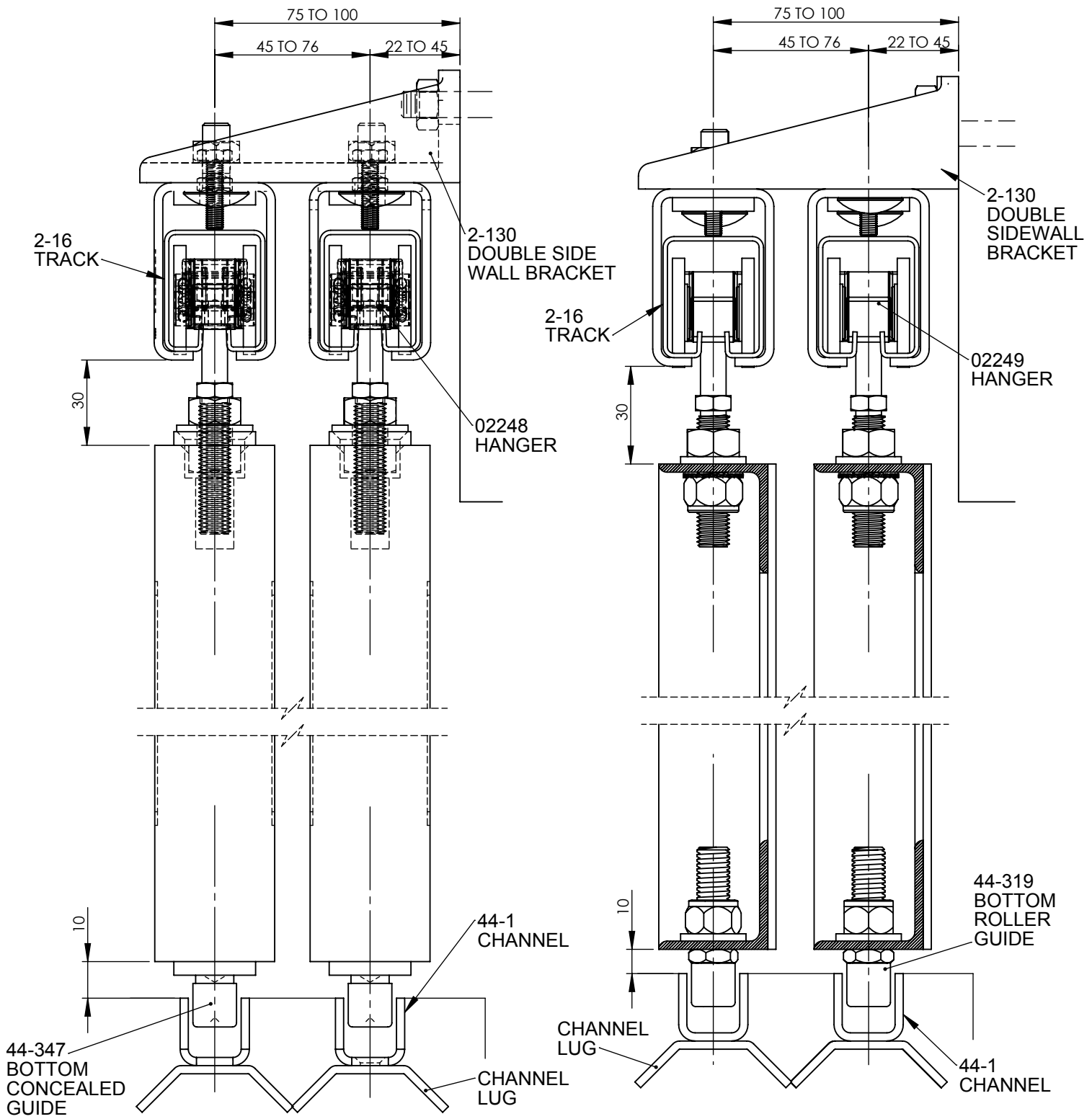

FIG.19



TIMBER DOOR SECTION

STEEL DOOR SECTION



Track End Stop 02718

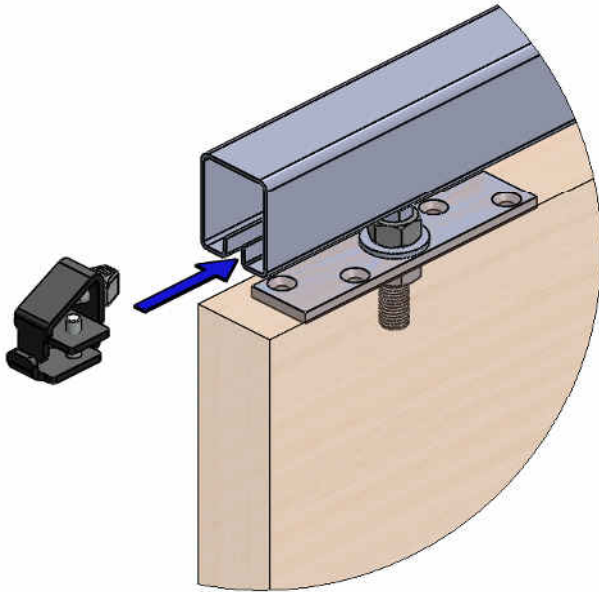

FIG.20

Note:
Fig21 shows the 02718 track stop is fixed flushed to the edge of the track.

Note:
In Fig20 blue arrow shows the 02718 track stop inserted into the track. Then use allen key to tighten the screws.

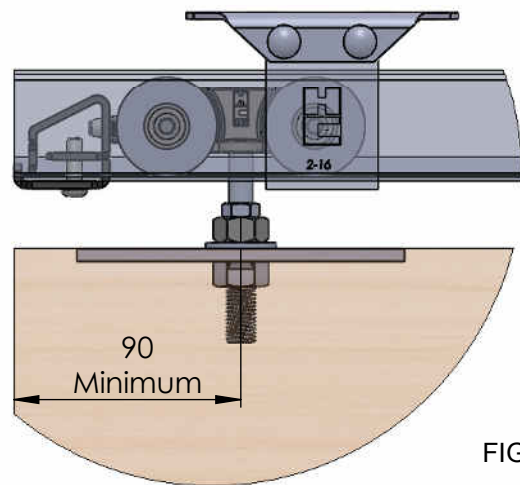

FIG.21

INSTALLATION AND MAINTENANCE INSTRUCTIONS:

Clean out channel, grease copiously inside of the top track and repeat at intervals.
Check all bolts, nuts and screws are securely tightened.

© HILLALDAM COBURN LTD
UNIT 16, MERTON INDUSTRIAL PARK
LEE ROAD, LONDON
SW19 3HX, ENGLAND
TEL: +44 (02)0 8545 6680
FAX: +44 (02)0 8545 6723
e-mail: sales@hillaldam.co.uk
www.coburn.co.uk

 **COBURN**
SLIDING SYSTEMS

The company reserves the right to make alteration in design and manufacture as they consider necessary without notice from time to time.